



#SayNoToMercury



# MERCURY FREE TECHNOLOGIES & EQUIPMENT HANDBOOK

- # Ore Processing Training Plant
- # Gravimetric Training Plants

*Prepared by: Convine OMONDI\_ Chief Technical Advisor\_planetGOLD Kenya.*

## INTRODUCTION

Ore Processing and Gravimetric Training Plants are expected to increase capacities for mercury-free ASGM through provision of technical assistance and technology transfer, being the core project's core mission of mercury elimination and adoption of alternative processing methods, monitoring and management of mine waste and effluents and show casing mercury-free processing alternatives. At mercury free training plants, miners will engage in hands-on mineral process on their own upon training by the project technical team.

Mercury-Gold Mass balance inventory will be conducted at each training plant to inform the project unit during monitoring of mercury reduction progress among the groups' operations. At least 1600 miners, a third of whom are women are expected to participate in the interventions, or about 260 miners from each project location. Target of 1.5 tonnes of mercury should be avoided by the closure of project period. Project indicators, call for at least 30% reduction of mercury emissions from the planetGOLD Kenya project locations.

Miners are expected to transit to mercury-free practices and adopt record keeping and reporting culture e.g. production tracking, economic modeling of their mining operations to help them develop bankable mine development models that will clarify risks, opportunities, and mercury free processing plant payback periods. Ores from the mine shafts and pits belonging to the project groups will be characterized in terms of ore assays and minor liberation tests at training sites to assist groups determine their production means, design processing strategies and economic models as they convert fully to mercury free practices. After undergoing technological trainings, mining groups/associations are expected to pool together and acquire processing equipment to operate, manage and process their ores collectively using their acquired mercury free equipment.

A processing training plant will be setup at Osiri-Matanda, Migori County, will have a full-scale ore process line, a gravimetric process line and a micro-leaching process line. The Osiri ore processing plant is expected to train 1705 miners belonging to four (4) mining associations; comprising of 14 mining groups and operating 46 mine shafts/pits and approximately 30 Tons of ore per day to the processing plant. The proposed ore process plant lines can optimally process ore with a continuous crushed and concentrate slurry flow rate of 10 Ton/hr.

Gravimetric training plants will be setup at Roasterman and Bushiangala (in Kakamega County), Chavakali-Vyalo and Kamlembe (in Vihiga County), Kehancha (in Migori County) and Lolgorian (in Narok County). The gravimetric plants expect to train miners' population ranging between 230 to 768, comprising of 5 to 15 mining associations and operating mine shafts/pits ranging to numbers 10 to 52. Expected ore to the gravimetric plants by respective mining associations is 10 Tons per day of ore for demonstrations and processing. All Gravimetric plants comprise process lines for both gravimetric equipment line and micro-leaching with an optimal continuous crushed and concentrate slurry flow rate of 5 Ton/hr.

The proposed layouts of project's mercury-free training plants' provide an elaborate waste management and tailing management plans. The project will ensure that only tested and approved eco-friendly leaching chemical and reagents are used.

Approximate Equipment and Installations cost is projected to USD 300,025.

Schematic Flow Diagram at the Ore Processing Training Plant

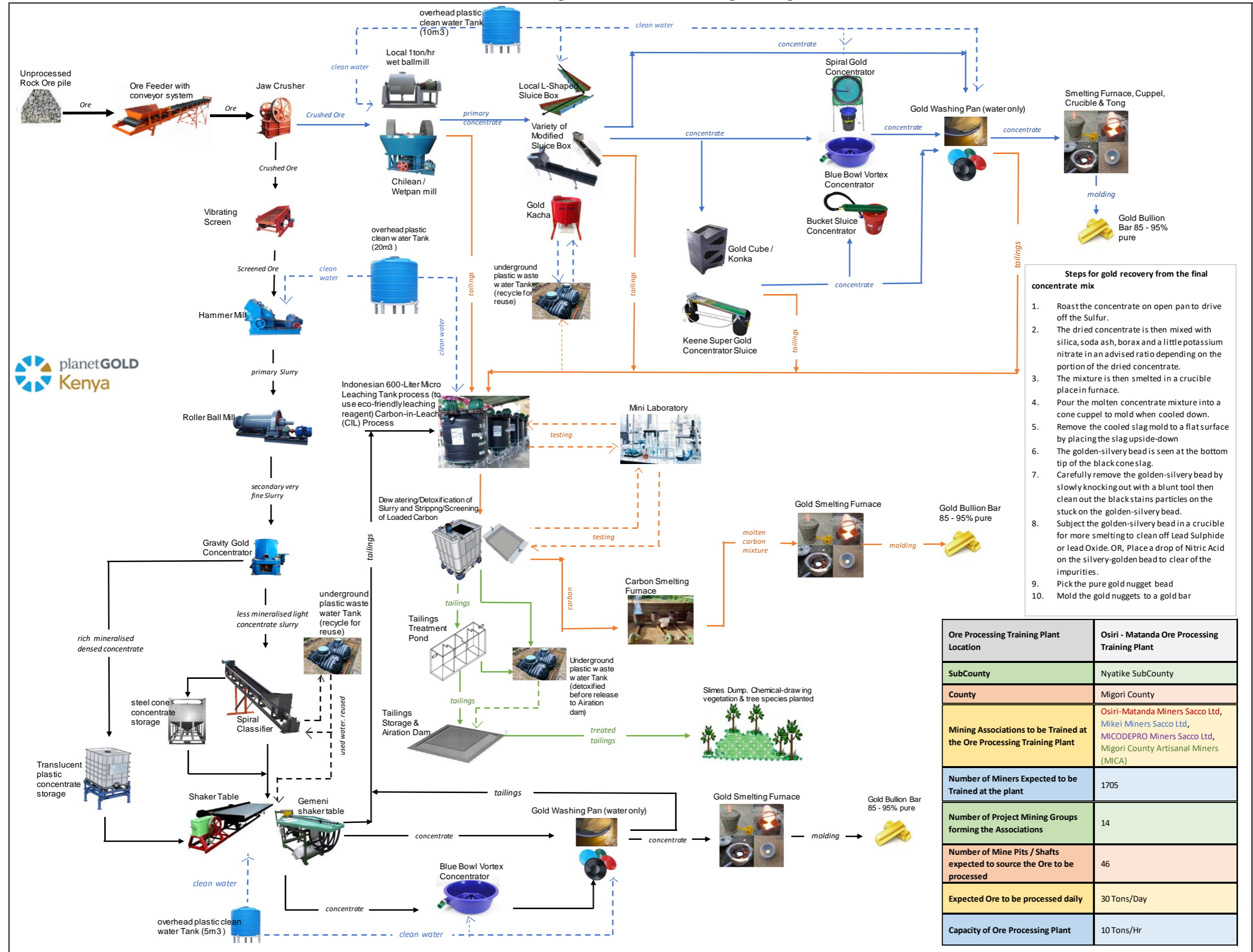

- Steps for gold recovery from the final concentrate mix**
1. Roast the concentrate on open pan to drive off the Sulfur.
  2. The dried concentrate is then mixed with silica, soda ash, borax and a little potassium nitrate in an advised ratio depending on the portion of the dried concentrate.
  3. The mixture is then smelted in a crucible place in furnace.
  4. Pour the molten concentrate mixture into a cone cuppel to mold when cooled down.
  5. Remove the cooled slag mold to a flat surface by placing the slag upside-down
  6. The golden-silvery bead is seen at the bottom tip of the black cones slag.
  7. Carefully remove the golden-silvery bead by slowly knocking out with a blunt tool then clean out the black stains particles on the stuck on the golden-silvery bead.
  8. Subject the golden-silvery bead in a crucible for more smelting to clean off Lead Sulphide or lead Oxide. OR, Place a drop of Nitric Acid on the silvery-golden bead to clear of the impurities.
  9. Pick the pure gold nugget bead
  10. Mold the gold nuggets to a gold bar

<b>Ore Processing Training Plant Location</b>	<b>Osiri - Matanda Ore Processing Training Plant</b>
<b>SubCounty</b>	Nyatike SubCounty
<b>County</b>	Migori County
<b>Mining Associations to be Trained at the Ore Processing Training Plant</b>	Osiri-Matanda Miners Sacco Ltd, Mikei Miners Sacco Ltd, MICODEPRO Miners Sacco Ltd, Migori County Artisanal Miners (MICA)
<b>Number of Miners Expected to be Trained at the plant</b>	1705
<b>Number of Project Mining Groups forming the Associations</b>	14
<b>Number of Mine Pits / Shafts expected to source the Ore to be processed</b>	46
<b>Expected Ore to be processed daily</b>	30 Tons/Day
<b>Capacity of Ore Processing Plant</b>	10 Tons/Hr



## TRAINING PLANTS EQUIPMENT LIST

### Ore Processing Training Plant Equipment List

#### Ore Processing Line

Item #	Description	UOM	Quantity	Comment	Required Capacity
1	1m <sup>3</sup> Feed Hopper/ Bin	unit	1	To be fabricated	5tph
2	300mm x 500mm Jaw crusher	unit	1	New complete with diesel engine power	7.5tph
3	Panel vibrating screen	unit	1	Complete with drive 10mm aperture screen.	5tph
4	2ft Hammer mill	unit	1	Complete with drive and electricals	7.5tph
5	Roller Ballmill	unit	1	Complete with drive and electricals	7.5tph
6	Spiral classifier	unit	1	Complete with drive and electricals	7.5
7	Steel cone concentrate storage	unit	1	To be fabricated	5m <sup>3</sup>
8	Translucent plastic concentrate storage	unit	1	Plastic Container on a steel stand	1 ton
9	Underground plastic waste water tank	unit	2	Plastic Tanks with complete piping and connectors	10m <sup>3</sup>
10	Shaker table	unit	1	Complete with drive and electricals (1-2 Ton/hr)	L4500mm x W1830mm
11	Gemeni shaker table	unit	1	Complete with drive and electricals (1-2 Ton/hr)	L2800mm x W1365mm
12	5m <sup>3</sup> Overhead clean plastic water tank	unit	1	Plastic Container on a 1m high steel stand	5m <sup>3</sup>
13	20m <sup>3</sup> Overhead clean plastic water tank	unit	1	Plastic Container on a 6m high steel stand	10m <sup>3</sup>
14	Blue Bowl Vortex Concentrator	set	1	Blue bowl kit c/w leg levelers, vial, pump, hose, battery clips, instructions and classifiers	Complete
15	Set of gold washing pan and kit	set	3	Complete set of small, middle, sifter and basin pan (3 color set)	Complete
16	Smelting Furnace & Briquette maker	unit	1	To be fabricated (as instructed), complete with Fan drive system	25kg capacity
17	Crucible, Tongs, Cuppel & Gold Molds	unit	1	Complete unit set	Complete
18	400mm Conveyor belts	m	120	Rubber belt (for use in fabrications)	120m long
19	Conveyor belt drives ( motor and gearbox)	units	7	3kW units will suffice	Complete
20	2 inch pipes	m	300	uPVC	300m
21	3 inch pipes	m	100	uPVC	100m
22	3/2 warman slurry pumps	units	5	Complete with drive and electricals	550 Watt 1Phase
23	Gold centrifugal gravity concentrator	units	1	Complete with drive and electricals	10tph

**Gravimetric Processing Line**

Item #	Description	UOM	Quantity	Comment	Required Capacity
1	1 ton/hr wet ball-mill	unit	1	To be fabricated	1tph
2	Chilean wet pan mill	unit	1	Complete with drive and electricals	10 tpd
3	10m <sup>3</sup> Overhead clean plastic water tank	unit	1	Plastic Container on a 6m high steel stand	10m <sup>3</sup>
4	Gold Kacha	unit	1	Complete with drive and electricals	3Ton/hr
5	Sluice Boxes Fabrications	unit	5	To be fabricated	1 t/hr
6	Underground waste water tank	unit	2	Plastic Tanks with complete piping and connectors	10m <sup>3</sup>
7	Gold Cube / Konka	unit	1	Complete with drive and electricals	1tph
8	Keene Super Concentrator Sluice	unit	1	Complete with drive and electricals	1 tph
9	Spiral Gold Concentrator	unit	1	Complete with drive and electricals	1 tph
10	Blue Bowl Vortex Concentrator	set	1	Blue bowl kit c/w leg levelers, vial, pump, hose, battery clips, instructions and classifiers	Complete
11	Bucket Sluice Concentrator	unit	1	Complete with drive and electricals	1 tph
12	Set of gold washing pan and kit	set	3	Complete set of small, middle, sifter and basin pan (3 color set)	Complete
13	Smelting Furnace & Briquette maker	unit	1	To be fabricated (as instructed), complete with Fan drive system	25kg capacity
14	Crucible, Tongs, Cuppel & Gold Molds	set	1	Complete unit set	Complete

**Leaching Processing Line**

Item #	Description	UOM	Quantity	Comment	Required Capacity
1	Indonesian 600-Liter Micro Leaching Tank	unit	2	Complete with drive, electricals and accessories	Complete
2	Leaching Chemicals & Testing Reagents	LS	LS	Assortment of laboratory Testing Reagents and eco-friendly leaching chemicals	Complete
3	Mini Laboratory	LS	LS	Assortment of laboratory Apparatus, Tools and Equipment	Complete
4	Detoxification Tank	unit	1	Complete with drive and electricals and detoxification chemicals	Complete
5	Tailings Treatment Pond	unit	1	Complete with dam liners and perimeter walling and all-round dyke	Complete
6	Underground waste water tank	unit	2	Plastic Tanks with complete piping and connectors	10m <sup>3</sup>
7	Carbon Smelting Furnace	unit	1	To be fabricated (as instructed), complete with Fan drive system	Complete
8	Smelting Furnace & Briquette maker	unit	1	To be fabricated (as instructed), complete with Fan drive system	25kg capacity
9	Crucible, Tongs, Cuppel & Gold Molds	unit	1	Complete unit set	Complete
10	Fresh Water Storage Tank	unit	1	Storage Capacity: 500L, 1500L, 3000L, 5000L,	Complete
11	500/600 Liter Steel Leaching Tank (To be locally Fabricated)	unit	1	To be fabricated	Complete

12	150/600 Liter Steel Leaching Tank (To be locally Fabricated)	unit	2	To be fabricated	Complete
13	Air Compressor for Smelting	unit	1	Complete with drive and electricals	8 Bar
14	Booster Water Pump	unit	1	Complete with drive and electricals (waste water pump)	1.5Hp
15	Fresh Water Pump	unit	1	Complete with drive and electricals	250 Watt 1Phase
16	Booster Submersible Water Pump	unit	1	Complete with drive and electricals	550 Watt 1Phase
17	Sump Box	unit	1	To be fabricated	100 L
18	Diesel-Powered Water Pump Generator	unit	1	Complete with drive and electricals	7 Hp

**Additional Equipments/Item**

Item #	Description	UOM	Quantity	Comment	Required Capacity
1	Temporary Store Structure (Iron-sheet)	LS	LS	As per site BoQ	Complete
2	Solar Lighting system & Security	LS	LS	As per site BoQ	Complete
3	Site Preparation of Plant Site & Layout for equipment installations	LS	LS	As per site BoQ	Complete
4	Briquette making Machine	set	LS	As per site BoQ	Complete
5	Miscellaneous for Fabrications & Materials	LS	LS	As per site BoQ	Complete

## Gravimetric Training Plant Equipment List

### ***Gravimetric Processing Line***

Item #	Description	UOM	Quantity	Comment	Required Capacity
1	1 ton/hr wet ball-mill	unit	1	To be fabricated	1tph
2	Chilean wet pan mill	unit	1	Complete with drive and electricals	10 tpd
3	10m <sup>3</sup> Overhead clean plastic water tank	unit	1	Plastic Container on a 6m high steel stand	10m <sup>3</sup>
4	Gold Kacha	unit	1	Complete with drive and electricals	3Ton/hr
5	Sluice Boxes Fabrications	unit	5	To be fabricated	1 t/hr
6	Underground waste water tank	unit	2	Plastic Tanks with complete piping and connectors	10m <sup>3</sup>
7	Gold Cube / Konka	unit	1	Complete with drive and electricals	1tph
8	Keene Super Concentrator Sluice	unit	1	Complete with drive and electricals	1 tph
9	Spiral Gold Concentrator	unit	1	Complete with drive and electricals	1 tph
10	Blue Bowl Vortex Concentrator	set	1	Blue bowl kit c/w leg levelers, vial, pump, hose, battery clips, instructions and classifiers	Complete
11	Bucket Sluice Concentrator	unit	1	Complete with drive and electricals	1 tph
12	Set of gold washing pan and kit	set	1	Complete set of small, middle, sifter and basin pan (3 color set)	Complete
13	Smelting Furnace & Briquette maker	unit	1	To be fabricated (as instructed), complete with Fan drive system	25kg capacity
14	Crucible, Tongs, Coppel & Gold Molds	set	1	Complete unit set	Complete

### ***Leaching Processing Line***

Item #	Description	UOM	Quantity	Comment	Required Capacity
1	Indonesian 600-Liter Micro Leaching Tank	unit	2	Complete with drive, electricals and accessories	Complete
2	Leaching Chemicals & Testing Reagents	LS	LS	Assortment of laboratory Testing Reagents and eco-friendly leaching chemicals	Complete
3	Mini Laboratory	LS	LS	Assortment of laboratory Apparatus, Tools and Equipment	Complete
4	Detoxification Tank	unit	1	Complete with drive and electricals and detoxification chemicals	Complete
5	Tailings Treatment Pond	unit	1	Complete with dam liners and perimeter walling and all-round dyke	Complete
6	Underground waste water tank	unit	2	Plastic Tanks with complete piping and connectors	10m <sup>3</sup>
7	Carbon Smelting Furnace	unit	1	To be fabricated (as instructed), complete with Fan drive system	Complete
8	Smelting Furnace & Briquette maker	unit	1	To be fabricated (as instructed), complete with Fan drive system	25kg capacity
9	Crucible, Tongs, Coppel & Gold Molds	unit	1	Complete unit set	Complete

10	Fresh Water Storage Tank	unit	1	Storage Capacity: 500L, 1500L, 3000L, 5000L,	Complete
11	500/600 Liter Steel Leaching Tank (To be locally Fabricated)	unit	1	To be fabricated	Complete
12	150/600 Liter Steel Leaching Tank (To be locally Fabricated)	unit	1	To be fabricated	Complete
13	Air Compressor for Smelting	unit	1	Complete with drive and electricals	8 Bar
14	Booster Water Pump	unit	1	Complete with drive and electricals (waste water pump)	1.5Hp
15	Fresh Water Pump	unit	1	Complete with drive and electricals	250 Watt 1Phase
16	Booster Submersible Water Pump	unit	1	Complete with drive and electricals	550 Watt 1Phase
17	Sump Box	unit	1	To be fabricated	100 L
18	Diesel-Powered Water Pump Generator	unit	1	Complete with drive and electricals	7 Hp

**Additional Equipments/Item**

Item #	Description	UOM	Quantity	Comment	Required Capacity
1	Temporary Store Structure (Iron-sheet)	LS	LS	As per site BoQ	Complete
2	Solar Lighting system & Security	LS	LS	As per site BoQ	Complete
3	Site Preparation of Plant Site & Layout for equipment installations	LS	LS	As per site BoQ	Complete
4	Briquette making Machine	set	LS	As per site BoQ	Complete
5	Miscellaneous for Fabrications & Materials	LS	LS	As per site BoQ	Complete

## SPECIFICATIONS OF MERCURY-FREE EQUIPMENT

Main focus of planetGOLD program is at the gold processing stage by the artisanal and small-scale miners. This handbook proposes mercury-free equipment and technology at Ore Liberation, Ore Crushing, Ore Screening, Ore Milling, Ore Concentration, Gold Amalgamation, Chemical Leaching, Tailing Waste Management and Mine Closure Management.

## ORE LIBERATION

Mineral liberation determines the processability of a particular mineral that could allow for concentration and processing. The test determines the ideal grain size the ore should be ground to in order to most efficiently liberate the gold from the ore matrix resulting to higher yields. A gravity or density separation procedure would necessitate liberation characterization based on the area percent of a mineral of interest in a particle, whereas a leaching concentration procedure would necessitate liberation characterization based on the free surface area percent (exposure on a particle surface) of a mineral of interest in a particle.

Liberation Test is necessary to be conducted on unknown ore type to determine the processing techniques to employ. planetGOLD Kenya project locations have known ore types and characteristics therefore minor liberation tests may be necessary at the training plants. Key tools for a fast simple liberation test include; a small ball mill, mortar and pestle, sledge hammer, a clock, a bucket, a washing basin or pond, sieves (5mm, 2mm, 1mm, 0.5mm, 0.1mm) and a weigh scale (up to 200kg).

Detailed liberation test is conducted by a Mineral Liberation Analyzer (MLA); this is a Scanning Electron Microscope (SEM) and equipped with Energy Dispersive X-ray (EDX) spectrometers, and computer software that automates microscope operation and data acquisition for automated mineralogy. MLA characterize the geometallurgical properties of an ore: Mineral abundance (modal analysis) and sample elemental distributions (assay), particle and grain size distributions, mineral associations, liberation and locking, theoretical grade-recovery curves, and particle densities and shape factors.

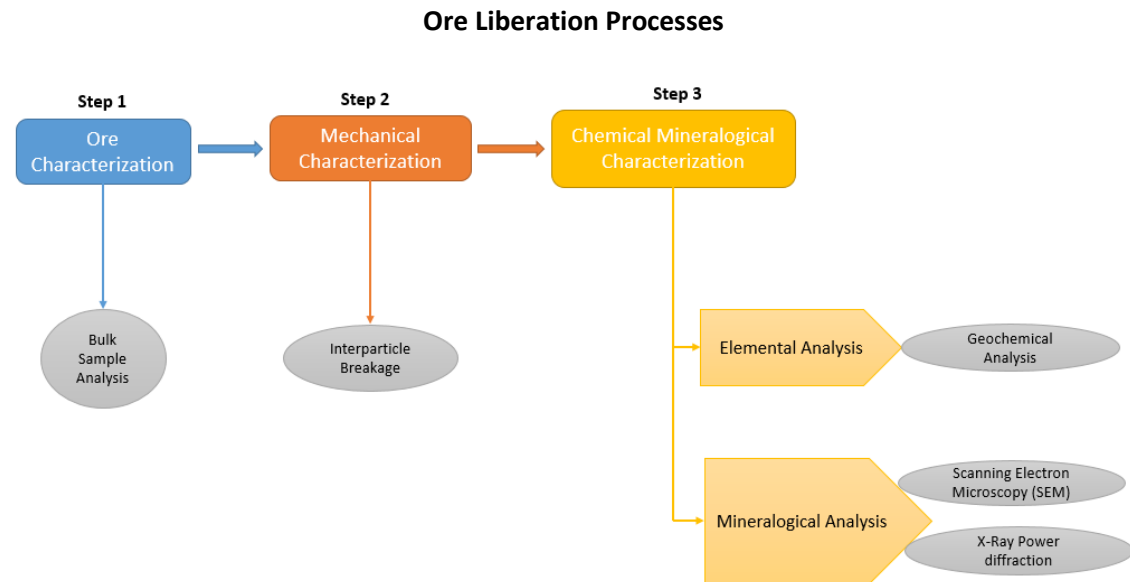

## ORE FEEDING EQUIPMENT

### Ore Feeder



**Description:** To be locally fabricated.

A 10 ton/hr Ore Feeder. 1 Ton bin complete with an inclined conveyor system

**Specifications:** 1m<sup>3</sup> Feed Hopper/ Bin

Belt width – 400mm

Belt Length – 16m

Power - 1.5kw

Belt speed – 1.3 m/s

Capacity – 20 tons

## ORE CRUSHING SYSTEM

### Jaw Crusher



**Description:** The jaw crusher adopts V-shaped cavity shape, large stroke, better crushing performance, large processing capacity.

All integrated on a structural steel stand. Ore is loaded via a conveyor from ore feeder bucket into the vibrating ore hopper, which feeds the jaw crusher. Material is crushed, typically to <1", and feeds onto the conveyor belt, which carries it to the next module.

**Specifications:**

Feed Open: - 200 x 400mm

Max. Feed Size: – 210mm

Discharge Size Range: – 20-60mm

Capacity: - 5-20 Ton/hr

Rotation Speed: - 260 r/min

Power Motor: - 15Kw

Weight: - 2.8 Ton

Overall size: - 1300x1090x1270mm

Complete with diesel engine drives.

## ORE SCREENING

### Single Deck Vibrating Screen

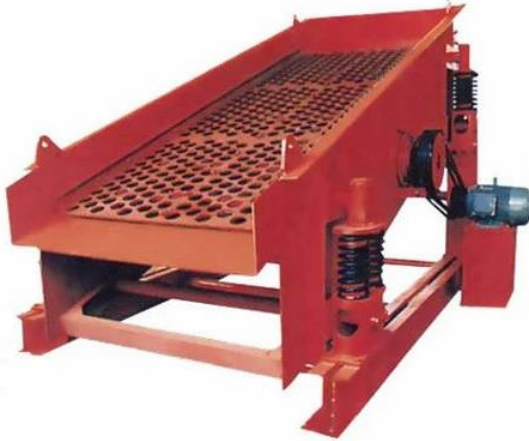

**Description:** This screen the crushed ore as it feeds to Hammer mill. Large-sized ores are re-crushed by Jaw Crusher.

**Specifications:**

Material: - Mild Steel  
Capacity: - 400 Kg/h  
Motor Power: - 5HP  
Automation Grade: - Automatic  
Voltage: - 220-415V  
Frequency: - 50-60 Hz

## ORE MILLING

### Hammer Mill

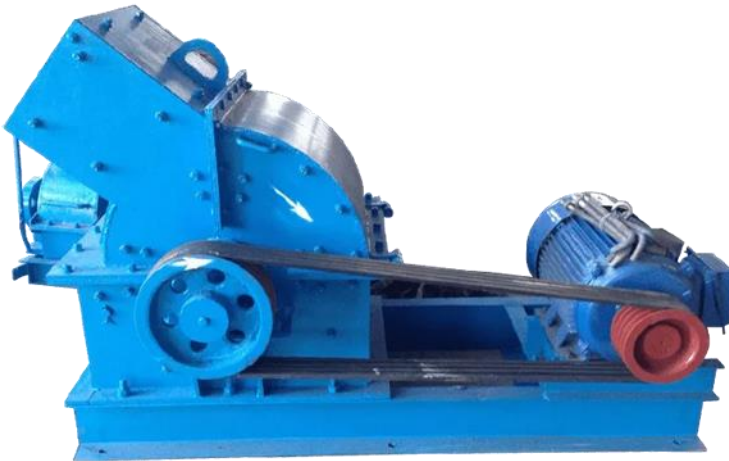

**Description:** Hammer mill crushes by the collisions between rotating high-speed hammers and materials. Has high reduction ration and high efficiency. Crushes both dry and wet brittle, medium-hard rock ore materials.

**Specifications:**

Capacity: - 5-10T/H  
Feeding Size: -  $\leq 50$ mm  
Discharge Size: -  $< 2.0$  mm  
Power: – Motor 25030 KW, Diesel 45HP  
Complete with spares and full set of hammers with screens and liners

### Roller Ball Mill

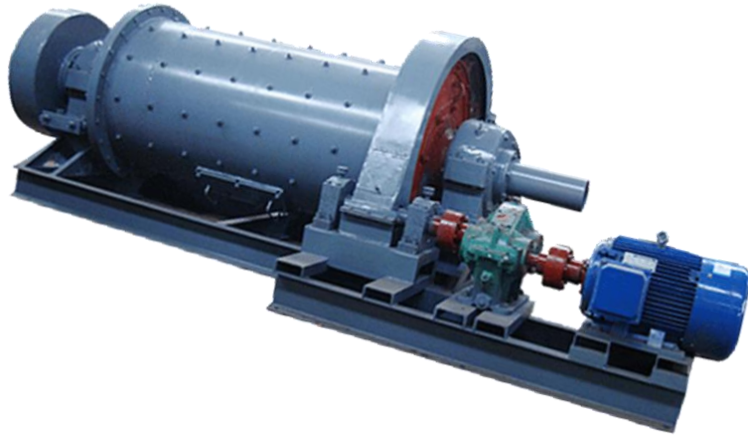

**Description:** Roller ball mill to grind 12mm input to 65 mesh output and the size is controlled using feed rate, water flow rate and a regrind circuit.

#### Specifications:

Rotational Speed – 24 r/min,  
Ball Weight – 18 ton  
Feeding Size - <25 mm  
Discharging Size – 0.074-0.4mm  
Capacity – 4-10 t/h  
Motor Power – 130 Kw  
Weight – 28 ton  
Water flow 42 – 59 liter/min,  
Equal Ball sizes and weights (all sizes range 2” x 6”

### Wet Ball Mill



**Description:** To be fabricated locally

Wet ball mill able to mill wet ore to slurry directed to locally modified sluice tables. Water is manually fed into the mill drum.

#### Specifications:

Drum dia. 1.5m  
Drum length 1.8 m,  
Capacity 1 ton/hr  
1000 Steel balls of different sizes: - small (40-60mm), medium (80mm), large (100-120mm), and super large (130-150mm).

35HP / 2400RPM Diesel Power Tiller Engine,  
Double Roll-Bearings, Output 35HP / 2200RPM,  
NET MASS 350KG, Water cooled.

### Wet Pan Mill / Chilean Mill



**Description:** Wet ball mill able to mill wet ore to slurry directed to locally modified sluice tables. Water is manually fed into the mill drum.

#### Specifications:

Dia. of grinding wheel: – 1200±10 mm  
Thickness of grinding wheel: – 200±20 mm  
Dia. of grinding pan: – 1800±20 mm  
Thickness of grinding pan: – 90±10 mm  
Width of grinding pan: - 230-250 mm  
Power: - 7.5 kw  
Rotary speed: - 10-13 r/min  
Input size: - < 30 mm  
Capacity: – 10 t/day

35HP / 2400RPM Diesel Power Tiller Engine, Double Roll-Bearings, Output 35HP / 2200RPM, NET MASS 350KG, Water cooled.

### MILLED ORE/TAILINGS FEEDER

#### Spiral Classifier



**Description:** Spiral Classifier primarily used to classify the slimes (fines) from a coarser, sandy sized material. It has an inclined trough with one or two spirals revolving slowly and free from touching the sides or bottom of the tank.

It separates out the smaller waste particles from the ore processor tailings. The larger particles can then be returned to the grinding circuit for finer grinding to liberate more values.

#### Specifications:

The auger is 12” diameter and 16’ long in a steel U trough.  
The motor is a 2 HP electric coupled to a gear reducer and a chain drives the auger.  
All bearings are mounted outside of the slurry to avoid damage by the grit  
The shaft seal at the lower end is a packing gland with Teflon packing.  
4 Tons/hr

## ORE GRAVITY CONCENTRATION

### Gravity Gold Concentrator



**Description:** The main parts of gold concentrator include feeding pipe, drain pan, main shaft, spring, motor, tailing discharge mouth, belt. high-speed pin create power centrifugal force, in the process of gravity separation, light material would be discharged, gold gathers.

**Specifications:**

Capacity: – 2-3 T/h  
Fluidization Water Required: – 3-5 m<sup>3</sup>/hr  
Slurry Water Required: – 5-7 m<sup>3</sup>/h  
Feeding Density: – 0-50%  
Feeding Size: – 0-3 mm  
Concentration Cleaning Up Cycle: – 1-3hrs  
Concentrate Weight: – 3.5 Kg  
Power Requirement: – 1.5 Kw  
Weight: – 380 Kg  
Dimensions: – 1160x885x1165 mm

### Gold Kacha



**Description:** Gold Kacha is a centrifugal concentrator that takes milled and screened ore and separation medium is water. Rotating cone (polyurethane lined) receiving prescreened feed material. The lighter material is washed down as tailing and the concentrate remains in the riffles of the cone for the washing down process.

**Specifications:**

Feed rate: - 1-3 Ton/hr  
Nominal Feed Size: - 3 mm  
Installed Power (Electric Motor): - 0.75kW  
Water Requirement: - 2-4 m<sup>3</sup>/h  
Typical Concentrate Weight: - 8-10 kg  
Run Time between Conc. Washes: - 1hr

## Shaker Table



**Description:** Shaking table are designed for wet gravity-based separation of minerals and other granular minerals.

**Specifications:** Deck size: – Length 4500mm, transmission end width 1830mm, concentrate end width 1530mm.  
 Maximum feeding size: – 0.15mm  
 Feeding Amount: – 15-25T/D  
 Feeding Density: – 15-25%  
 Stroke: – 8-16mm  
 Frequency: – 50-57f  
 Water Added: – 10-17t/d  
 Transverse slope of Deck: - 1<sup>0</sup>-2<sup>0</sup>  
 Beneficiation area: – 7.6m<sup>2</sup>  
 Cross-Section shape of deck: – Triangle  
 Motor: – 120V, Single Phase: – 1/2Hp, 110V, (1.1Kw)

## Gemini Shaker Table

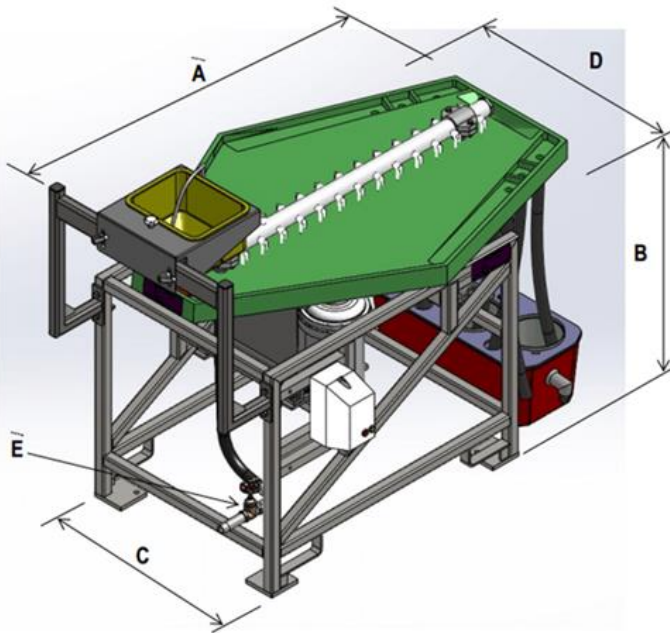

**Description:** The Gemini Table has been specifically designed for the recovery of fine gold to a directly smelttable concentrate. The direct drive system incorporates a geared motor, driving a crank connected to the table deck. The crank includes a spring connection system to absorb overrun. The bump stop system provides a fine-tuning mechanism. Table tuning is achieved by adjusting a single screw.

**Specifications:**  
 Capacity: – up to 1-2 ton/hr  
 Dimensions: - A-2800mm, B-1365mm, C-916mm, D-1750mm, E (wash water)-38 Ltr/min.  
 Approximate packed weight: – 540kg.  
 Feed nominal: – 450 kg/h  
 Feed density recommended: – 60-70% solid w/w  
 Feed size nominal top: – 800-1000 microns  
 Nominal wash water requirement: – 38 Ltr/min  
 Nominal wash water pressure: – 30 kPa

## Modified Sluice Boxes



**Specifications:** To be locally fabricated as specified.

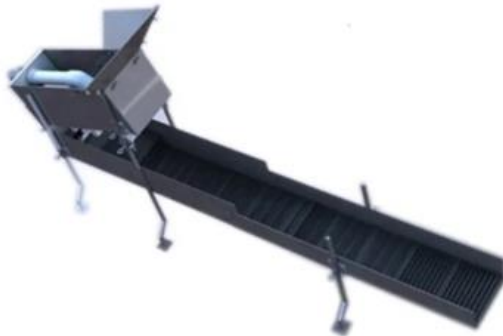

## Gold Cube / Konka



**Description:** The Gold Konka/Cube consists of several sluices connected in a zig-zag pattern. The sluices are lined with vortex mats. The material is fed manually into the top Gold Cube Trommel and washes down several sluices (i.e., usually four in the processing system). After a batch is complete, sluice modules are washed down into a container to release the concentrate for further upgrade.

It offers a more sophisticated & mechanical solution to traditional sluices, whilst remaining easy to operate. Vortex matting covering the surface of each tray, offering high upgrade ratios ensuring that even the finest gold particles are caught.

### Specifications

Feed rate (Kg/h): - 450  
Installed Power: - 12Volt car battery  
Nominal Feed Size (mm): - 3  
Water Requirement (m<sup>3</sup>/h): - 4  
Gold Cube Trommel Features:- Low energy 12v gear motor, 3/16th Punch Plate, Adjustable pitch, Extremely well built, Mounting template included

## Spiral Gold Concentrator



Rear View of GW25

**Description:** Spiral Gold Concentrator recover ultrafine gold better than anything you have ever seen before. This amazing recovery is due to its soft rubber spiral wheel that has an extremely cupped sharp edge riffle. Experience precise and smooth speed control with its long life replaceable geared bearings spiral wheel. Equipped with electrical back panel with speed control, plug in battery, pump terminals and on/off switch. Another unique feature is the metered gold tube that easily screws into the back of the wheel to remove values and a black sand collection funnel to collect a first run of concentrates. The water flow tube has metered water jets for precise flow. Set up by inserting three stainless steel legs and connect a 12 v battery.

### Specification:

750 gallons per hour,  
12-volt pump,  
Wash down hose and nozzle,  
Filter sieve and  
A solid recovery pan,  
Capacity up to 400 lbs. per hour

## Keene Super Gold Concentrator Sluice



**Description:** Hungarian riffle (Miracle Mat) molded into a rubber mat and built into a portable concentrator sluice measuring 44 inches long by 8 inches wide with built in header box, plumbed with an adjustable flow valve to meter water flow and separate spray nozzle for clean-up.

Equipped with adjustable brackets, two 5 gallon buckets and a 12 volt 1100 GPH pump.

Operates for 8 hours on a typical automobile battery. Battery not included.

### **Specifications:**

Capacity: - 100 lbs. per hour  
Net Weighs:- 25 lbs.

## Bucket Sluice Concentrator



**Description:** Geo Sluice Mining Bucket Sluice Concentrator Combo Gold Recovery Clean Up. Comes with Hose, Water Adjuster, Sluice, Pump and hose attachment.

### **Specifications:**

Green Bucket Sluice Concentrator and a 500 GPH Pump, 3 Ft Special Hose, Water Valve, Hose Fitting, and Bungees for mounting to a bucket. 1/8 inch ABS plastic. A Battery

## Blue Bowl Vortex Concentrator



**Description:** The blue bowl gold concentrator is completely portable and will quickly remove your fine gold from your concentrates. It is designed to work forever, with no moving parts to wear out or break.

**Specifications:** Concentrator kit includes the blue bowl, 3 plastic leg levelers, 1/4 ounce plastic vial, 750 g/h 12V pump, 3' of 3/4" hose, battery clips, instructions and 4 classifiers

Pre-screened concentrates to at least 30-mesh using a classifier before adding to your blue bowl.

To recover micro-fines, prescreen the concentrates using a 50 or 100 mesh classifier.

Panning fine gold concentrates by hand is difficult and tedious. The blue bowl can recover gold as fine as talcum powder

## STORAGE OF CONCENTRATE, CLEAN WATER & WASTE WATER

### Temporary Concentrate Storage Tanks

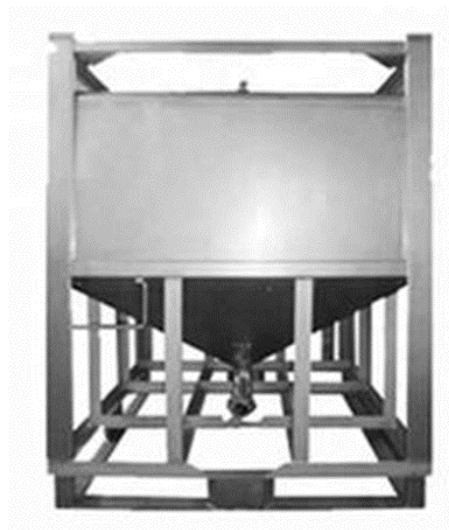

**Specifications:**

Temporary storage for overflowing concentrates  
1 Ton plastic tank for slurry concentrate  
2 Ton steel tank. (to be locally fabricated as specified)

### Fresh & Clean Water Storage Tank



**Specifications:**

3 Layer & 5 Layer Plastic Hydro-Plus Plastic Water Tanks

Storage Capacity: - 500L, 1500L, 3000L, 5000L, 10000L, 20000L

Layer Type: - 3 Layer, 5 Layer

Material: - Plastic

Color: - Green, Blue, Black, White

Usage/Application: - Fresh & Clean Water Storage

Shape: Round

### Septic Waste Water Storage Tank



**Specifications:**

Underground Septic Wastewater plastic tanks for recycling and basic treatment

Storage Capacity: Twin Tanks @5000L,

Layer Type: 3 Layer/5 Layer

Material: Plastic

Color: Black,

Environmentally friendly

## Gold Washing Pan & Gold Pan Kits



### Specifications:

Adopt 90°rifled design to ensure safe, reliable and rapid recovery of gold under wet or dry conditions. Lightweight pans, varied colors that enhance gold nugget visibility, and virtually indestructible.

Condition: 100% Brand New

Material: Plastic

Color: Green, Blue & Black

Small Gold Pan Size: Approx. 26.5cm / 10in

Middle Gold Pan Size: Approx. 35.5cm / 14in

Gold Sifter(sieved) Size: Approx. 35cm / 13.8in

Gold Basin Size: Approx. 38cm / 15in

Weight: Approx. 1332g / 47oz

## SMELTING FACILITY

### Crucibles & Tongs & Gold Molds



### Specifications:

Fused Silica smelting Crucibles (sizes 150 – 300 oz)

Clay Graphite Crucibles (sizes A10 – A20)

Scissor Tongs (14" – 18")

Bent Tongs (19")

Devil Forge Tongs

Gold Molds

Conical Slag Removal Mold

## Gold Concentrate Smelting Furnace



**Description:** To be locally fabricated

### **Specifications:**

Stainless steel container – anything from a brake drum to a charcoal BBQ grill  
40 mm M6 bolts and washers and bolts  
Steel pipe for air supply  
Plaster of Paris  
Sand – clean beach sand, play sand, or kiln sand  
Power drill and 6mm drill bit  
Charcoal / briquette  
Air source – hand crank blower, bellows, or air compressor

## Charcoal Briquette Machine



**Description:** Fuel Cow  
Dung Manure Charcoal  
Briquette Compressing  
Making Machine  
Pulverized Compressed  
Coal Briquetting Forming  
Machine

### **Specifications:**

Fuel: - Diesel  
Power: - 10HP  
Speed: - 15r/min  
Capacity: - 1-1.5t/h(charcoal); 3-4t/h(coal)  
Roller Diameter: - 300mm  
Dimension: 1750\*1000\*1260mm  
Weight:- 350KG

## Carbon Smelting Furnace

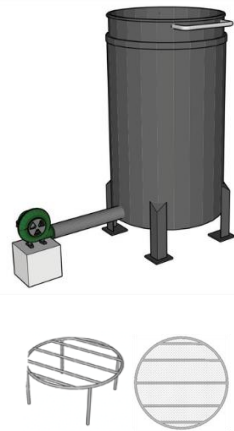

**Description:**  
To be locally fabricated

### Specifications:

- Material: Carbon Steel
- Size: Tube: diameter 500 mm high 800 mm, 10 mm Thickness
- Iron Furnace: Diameter 480 mm, Rebar Diameter 13 mm height 250 mm
- Without wheels
- Completed with:
  - Air pump, Blower model 2 "snail, Power: 150 watts
- Concrete block: (Length x width x height) 150 mm x 150 mm x 110 m and Concrete grade K175
- Size: (Length x width x height) 150 mm x 150 mm x 110 m
- Frame/Column: Angle Steel 40 mm x 40 mm x 4 mm, Length 200 mm
- Base Plate: (Length x Width x Thickness) 70 mm x 70 mm x 10 mm
- Without bolt

## Assortment of laboratory Apparatus, Tools and Equipment



### Laboratory Items

Sieve & Vibrating Sieve Shaker Machine (sieves 5mm, 2mm, 1mm, 0.5mm and 0.1mm), Beakers, Test tubes, Graduated Cylinders, Flasks, Tongs, Evaporation dishes, Funnels, Crucible, Mortar & Pestles, Alcohol Burners, Burets, Tweezers, Droppers, Watch Glasses, Condensers, Kipps Apparatus, Thermometers, Iron Stages, Glass Rods, Ladles, Rubber tubes & plugs, Microscope, Racks, Bunsen Burner, Retort, Pipettes, Spatulas, Beakers, Syringes, Magnets, Stands, Bucket, Basins, Clocks, weighing scale, Calculators, ph meters, Lab Scale Ball Mill for milling Laboratory samples, etc.

**MICRO LEACHING FACILITY**

**Indonesian 600 Liter Micro Leaching Tank**



## Designs & Specifications of Micro Leaching Tank

- Height: 1,58 meter
- Diameter: 0,865 meter
- Inlet: 3/4 inch
- Outlet: 1 inch
- Drain: 1 inch
- Wall Thickness: 8 mm - 11 mm

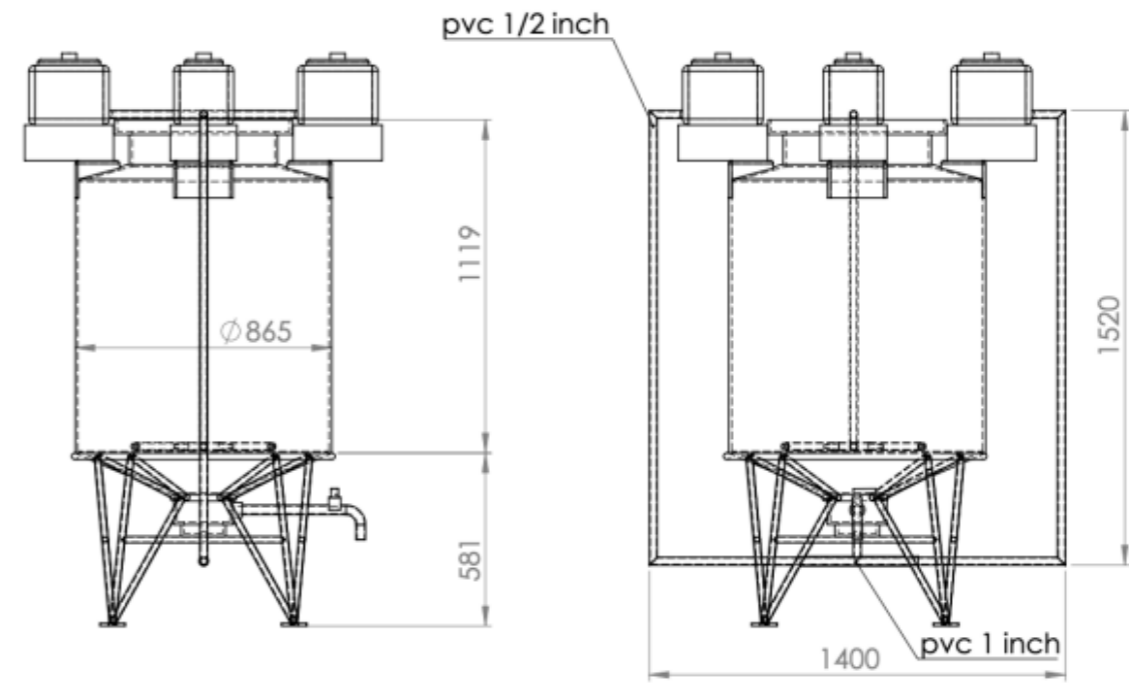
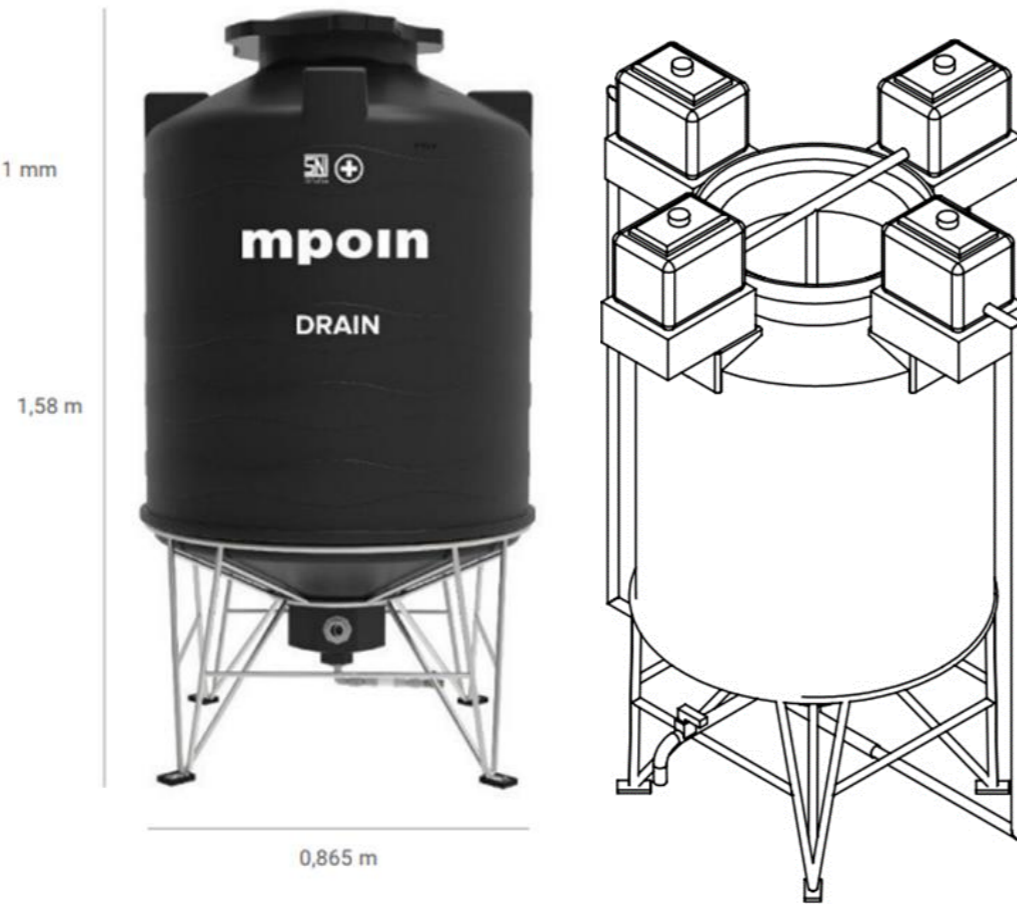

- Unit is in millimetres, otherwise it is specified.

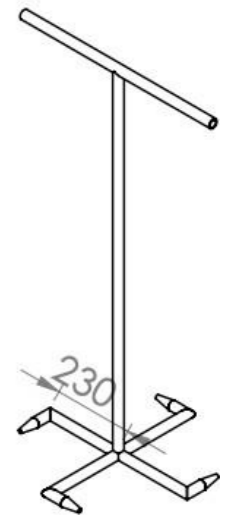
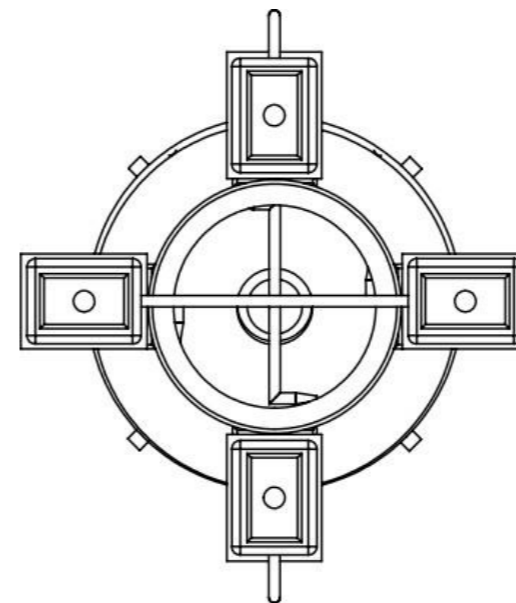

## ASSEMBLY INSTRUCTIONS OF MICRO LEACHING TANK

1. Prepare all the necessary equipment and materials, and use personal protective equipment such as gloves.
2. Cut 6 wooden boards measuring 25 cm x 24 cm using a wood saw. (Figure 1)
3. Place the board at the air pump installation location estimating the location of the hole.
4. Drill 3 holes measuring 10 mm in the board with a drill estimating the location to attach the nuts and bolts to the water tank. (Figure 2) The board is placed horizontally to the water tank on a different side from the outlet hole.



Figure 1.



Figure 2.

5. Drill a hole measuring 10 mm on the water tank on the same location as the board using a drill (Figure 3).
6. Install the bolts and nuts in the holes that have been made to attach 1 board to the water tank (Figure 4).



Figure 3



Figure 4

7. Perform Steps 5 and 6 on the opposite side of the water tank (Figure 5).

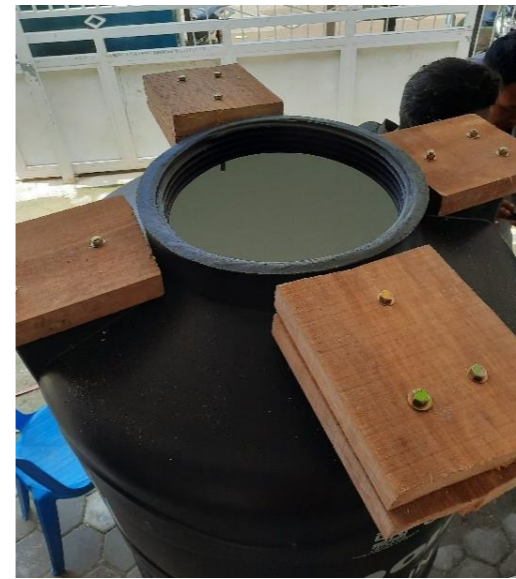

Figure 5



Figure 6

8. Drill holes measuring 10 mm on the other 2 sides of the water tank with a drill according to the holes on the board.
9. Place the bolts and nuts in the holes made in step 8 to attach the 2 boards to the water tank.
10. For pumps using 1 board install the water pump pipe facing outwards, and facing inwards for pumps using 2 boards.
11. Install the 1 inch to ½ inch PVC external thread reducer sock in the water tank outlet hole pointing downwards and seal with tape. (Figure 7).
12. Cut a ½ inch pipe as required as a connector with a ½ inch tee connection and attach it. (do not glue first)
13. Cut 2 pieces of ½ inch pipe measuring 14 cm in length to connect from the ½ inch tee that was installed in Step 12 (Figure 8).



Figure 7



Figure 8

14. Attach a ½ inch watermooor to the end of the pipe that was installed in Step 13.

15. Cut 2 pieces of ½ inch pipe measuring 35 cm in length to connect from the watermoor that was attached in Step 14.
16. Attach a 90-degree knee to the end of the pipe that was installed in Step 15 facing upwards(Figure 9).
17. Cut and attach a ½ inch pipe (connection part) measuring 5 cm in length at both ends of the water pump outlet that are facing outwards sealed with pipe seal tape inside.
18. Attach the watermoor on the pipe that was installed in Step 17.
19. Cut and attach a ½ inch pipe measuring 5 cm in length as a connection between the ½ inch watermoor, and connect it with the ½ inch knee downwards (Figure 10).



Figure 9



Figure 10

20. Connect the knee that was installed in Step 16 with a ½ inch pipe and connect to the knee that was installed in Step 19. Adjust the length of the ½ inch pipe used and make sure the pipe is installed vertically. (Fig. 11)



Figure 11



Figure 12

21. Glue the pipe joints, knees, watermoors, tees and reducers that have been installed in steps 11 to 20 with pipe cement.
22. Take a 5-way pipe connector and attach ½ inch pipes measuring 4 cm in length on all four sides (Figure 13).
23. Connect the four ½ inch pipes that were installed in Step 22 with a watermoor and connect to a 14 cm ½ inch pipe (Figure 14).



Figure 13



Figure 14

24. Connect the four pipes that have been installed in Step 23 to ½ inch knees facing according to the figure.
25. Cut the ½ inch pipe as required and cut the plastic centrifuge tube at the pointed end so that it becomes hollow.
26. Connect the pipe that has been cut with the plastic centrifuge tube that has been cut and use the seal tape.
27. Connect the series of connectors, pipes, watermoors and knees that have been installed in Steps 22 to 26 with pipe cement (Figure 15).
28. Attach a ½ inch pipe measuring 5 cm in length at the connector section to the water pump outlet that leads into the water tank with seal tape.
29. Connect a watermoor to each pipe that was installed in Step 28.
30. Connect to a ½ inch pipe and ½ inch tee downward in the tank adjusting the pipe length to the length of the connector between the pipes, make sure the tee is located in the middle of the water tank.
31. Take the series of pipes that have been glued in Step 27, connect them to a long pipe and insert the series of pipes into the water tank until they touch the bottom of the tank, the vertical pipe joint is connected to the series of pipes in Step 31, then cut the pipe according to the length required.
32. Connect the circuit that was installed in Steps 28 to 31 with pipe cement (Figure 16).



Figure 15



Figure 16

33. Allow a few moments for the pipe cement to dry completely.
34. Attach a 1-inch outlet pipe to the water tank outlet that leads out of the tank with the thread sock, faucet and knee downwards. Apply pipe cement and use seal tape on the circuit.
35. Connect the water pump to a power source and start a leak test on the tank circuit.

**Requirements for Construction of 4 pcs of Micro-Leaching Tanks to be installed at each gravimetric or ore processing training plant**

No	Materials Needed	Quantity
1	Water tank drain 600 liters MPOIN	4 pcs
2	PVC pipe AW ½ inch (RUCIKA or equivalent)	3 pcs (@ 4 meters)
3	PVC pipe AW 1 inch (RUCIKA or equivalent)	1 pc (@ 4 meters)
4	Water moor ½ inch (RUCIKA or equivalent)	11 pcs
5	Water moor 1 inch	2 pcs
6	Air pump LP 100 RESUN	4 units
7	Sandpaper medium size	1 sheet
8	Pipe cement	1 can (@ 400 grams)
9	Nylon cable 40cm x 4.8cm	1 pack (@100 pcs)
10	PVC knee 90 degrees ½ inch	6 pcs
11	AW tee ½ inch	2 pcs
12	External thread reducer sock PVC 1 inch to ½ inch	2 pcs
13	External thread sock 1 inch	2 pcs
14	Internal thread sock 1 inch	2 pcs
15	PVC pipe wrap tape ½ inch x 10 meters	4 pcs
16	Cable tape ¾ inch x 25 meters	1 pc
17	Electric drill	1 pc
18	Drill bit diameter 10 mm	1 pc
19	Genset 1,5 KW	1 unit
20	External thread faucet stop valve 1 inch	1 pc
21	Wooden board or plywood (2400 mm x 1120 mm)	1 pc
22	Bolts, rings, nuts (bolt size: length 15 cm, diameter 10 mm)	20 pcs
23	Cable reel 5 plugs 5 meters	2 pcs
24	Voltage stabilizer 1500VA	1 pc
25	Stainless steel filter mesh 200	1 pc

No	Materials Needed	Quantity
26	Stainless steel filter mesh 35	1 pc
27	Plastic basin, capacity 15 liters	2 pcs
28	Plastic barrel, capacity 120 liters with chrome handles	3 pcs
29	PVC pipe saw	1 unit
30	Wood hand saw	1 unit
31	Water hose (diameter 2 inches, length 2 meters, color transparent)	1 pc (@ 2 meters)
32	Clamp that fits 2 inch hoses	1 pc
33	Water hose (diameter 1/2 inch, length 4 meters, color transparent)	1 pc (@ 2 meters)
34	Clamp that fits 1/2 inch hoses	1 pc
35	Faucet adapter to ½ inch water hose	1 pc
36	5 way ½ inch pipe connector	2 pcs
37	Plastic centrifuge tube 15 ml	8 pcs
38	Cloth gloves	1 box
39	Latex / rubber gloves	1 box
40	Pipe wrench 24 inch	1 unit
41	Measuring tape 5 meters	1 pc

## Leaching Operation Guide: Gold Leaching Process, Cyanide- Containing Tailing Management and Free Cyanide Analysis

The gold leaching process consists of the following steps:

### 1. CRUSHING AND GRINDING

#### a. Introduction

Process to reduce ore size to obtain ore size of less than 0.074 mm or passes a 200 mesh sieve. A rodmill, crusher, ball mill, hammer mill and other grinding crushing equipment can be used.

#### b. Process Parameters

- Output: Ore size  $\geq$  200 mesh or  $\leq$  0.074 mm
- Composition of ball mill volume:

Steel balls	30% of ball mill volume
Air	20% of ball mill volume
Ore and water	50% of ball mill volume
Water	40% ore weight

- Ball mill rotation speed is based on the table below

Diameter ball mill (m)	Critical speed (rpm)	Optimum speed (rpm)
1.5	35	24
1	42	30
0.9	45	31
0.8	47	33
0.7	51	35
0.6	55	38
0.5	60	42
0.4	67	47

#### c. Steps

1. Grind for approximately 6-8 hours (depending on the hardness of the ore).
2. Filter the sludge from the ball mill with a 200 mesh sieve.
3. Place the sludge that passes the 200 mesh filter into the leaching tank.

### 2. CRUSHING AND GRINDING

#### a. Introduction

Process for dissolving gold using cyanide in a tank equipped with a stirrer

and air blower and the dissolved gold is absorbed with activated carbon.

#### a. Steps

1. Turn on the power source so that the stirrer in the tank rotates.
2. Place the ore sludge into the leaching tank
3. Turn on the blower so that air bubbles form in the leaching tank.
4. Add lime little by little until the pH of the sludge reaches 10.5 - 11. While adding lime, measure the pH using a pH meter / litmus paper. Make sure this step is done before adding the sodium cyanide.
5. Pour sodium cyanide (NaCN) into the leaching tank according to the following table:

- Table of Chemical Requirements for Low Grade Gold Ores (<30 ppm) in the Leaching Process

No	Ore (medium sack)	Ore (big sack)	Ore (kg)	Slurry(*) (liter)	NaCN (kg)	Active Carbon (kg)	Active Carbon (sack)	PbNO <sub>3</sub> (gram)
1	0.3	0.2	10	15	0.015	0.04	0.0016	0.75
2	3	2.2	100	150	0.15	0.4	0.016	7.5
3	5	3.3	150	225	0.2	0.6	0.02	11.25
4	33	22.2	1,000	1,500	1.3	4	0.16	75
5	50	33.3	1,500	2,250	2	6	0.24	112.5

Note: (\*) 40% solid, 60% water

- Table of Chemical Requirements for Medium Grade Gold Ore (30-50 ppm) in the Leaching Process

No	Ore (medium sack)	Ore (big sack)	Ore (kg)	Slurry (*) (liter)	NaCN (kg)	Active Carbon (kg)	Active Carbon (sack)	PbNO <sub>3</sub> (gram)
1	0.3	0.2	10	15	0.03	0.1	0.0032	0.75
2	3	2.2	100	150	0.3	1	0.032	7.5
3	5	3.3	150	225	0.4	1.2	0.05	11.25
4	33	22.2	1,000	1,500	2.6	8	0.3	75
5	50	33.3	1,500	2,250	4	12	0.5	112.5

Note: (\*) 40% solid, 60% water

Note: Do not treat mercury waste with cyanidation.

- Table of Leaching Process Chemical Requirements for High Grade Gold Ore(>50 ppm)

No	Ore (medium sack)	Ore (big sack)	Ore (kg)	Slurry (*) (liter)	NaCN (kg)	Active Carbon (kg)	Active Carbon (sack)	PbNO <sub>3</sub> (gram)
1	0.3	0.2	10	15	0.05	0.2	0.01	0.75
2	3	2.2	100	150	0.45	2	0.1	7.5
3	5	3.3	150	225	0.7	3	0.12	11.25
4	33	22.2	1,000	1,500	4	20	1	75
5	50	33.3	1,500	2,250	6	30	1.2	112.5

Note: (\*) 40% solid, 60% water

6. Measure and record the following:

- pH
- Dissolved oxygen (DO)
- Amount of sodium cyanide (NaCN) added
- Stirrer rotation speed (stirrer speed is set at around 100 rpm)
- The time or hour when the leaching process is started

7. Measure the pH and DO once every hour for the first 3 hours, then measure every 6 hours. Add lime if the pH is less than 10.5. **Make sure the pH is always in the range of 10.5 – 11.0. If the pH is < 10.0, cyanide gas (HCN) will be formed and it is very dangerous. If the pH is > 11.0, the gold recovery will decrease.**

8. 6 hours after the cyanide has been added, add activated carbon measuring larger than 1 mm into the leaching tank.

9. After the activated carbon is added, reduce the stirrer rotation speed to about 40 rpm

10. 42 hours after the activated carbon has been added, remove the sludge that has been mixed with the activated carbon from the leach tank.

11. Separate the activated carbon from the sludge and wash the activated carbon with water until there are no impurities.

12. Dry the activated carbon in the open air.

13. Place the activated carbon that has been dried into the furnace, the activated carbon is roasted until it becomes ash and the ash is smelted down to become bullion.

**2. WASHING AND ROASTING GOLD-CONTAINING ACTIVATED CARBON**

- Separate the activated carbon from the sludge and wash the activated carbon with water until there are no impurities.
- Dry activated carbon in the open air.
- Place the activated carbon that has been dried into the furnace, the activated carbon is roasted until it becomes ash and the ash is smelted down to become bullion.

## Additional Micro-Leaching Parts & Items

### 500/600 Liter Steel Leaching Tank (To be locally fabricated)



#### Specifications:

- Material: Stainless Steel
- Capacity: 250 kg of ore, 500/600 L of slurry
- Beam: UNP 100x50x6
- Column: UNP 100x50x6
- Bracing: UNP 100x50x6
- Base Plate
- Dimension: Length x Width x Thickness (160 x 150 x 10) mm
- Bolt: 16 pcs, Diameter 16 mm
- Completed with:
  - 2 pcs Aerator [ref. item no. 6] + compatible rubber hose (5 meters)
  - 1 set Agitator Stirrer
  - 1-unit Agitator Motor
  - Steel Stair

### Agitator Stirrer for The 500/600-liter Scale Leaching Tank

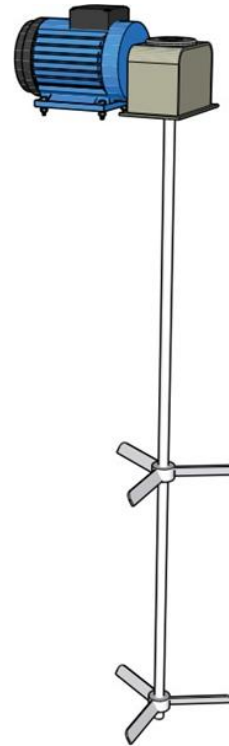

#### Specifications:

Consisting of:

- Stirrer:
  - Material: SS 316 stainless steel
- Impeller:
  - 2 pairs of type 316 stainless steel graded blades
  - Diameter: 250mm
  - Thickness: 4 mm
  - Impeller-type hydrofoil
  - Finishing mechanical polish
  - material mixer SUS 304
- Agitator shaft:
  - Dimension: Length 1500 mm Diameter 30 mm
  - Double blade
  - Finishing mechanical polish
  - material mixer SUS 304
- Electric Motor:
  - Power source: 3 phases 3 HP / 2.2 kW electric motor, 380 Volt, 50 Hz, 4 poles
  - Type: Horizontal
  - RPM: 1500 rpm
- Speed control inverter:
  - Inverter 2.2 KW 380V 3 Phase Variable Frequency Motor Drive Speed Controller
  - Output: 3PH 0-500Hz
  - Control Method: voltage vector,
  - Braking Resistor: 250Ω
  - Rated voltage: three-phase AC380-440V
  - Brand Schneider or Equivalent
- Gearbox inducer:
  - Type: helical gear ch01 or Equivalent
  - Ratio 1:4

## 150/200 Liter Steel Leaching Tank (To be locally Fabricated)

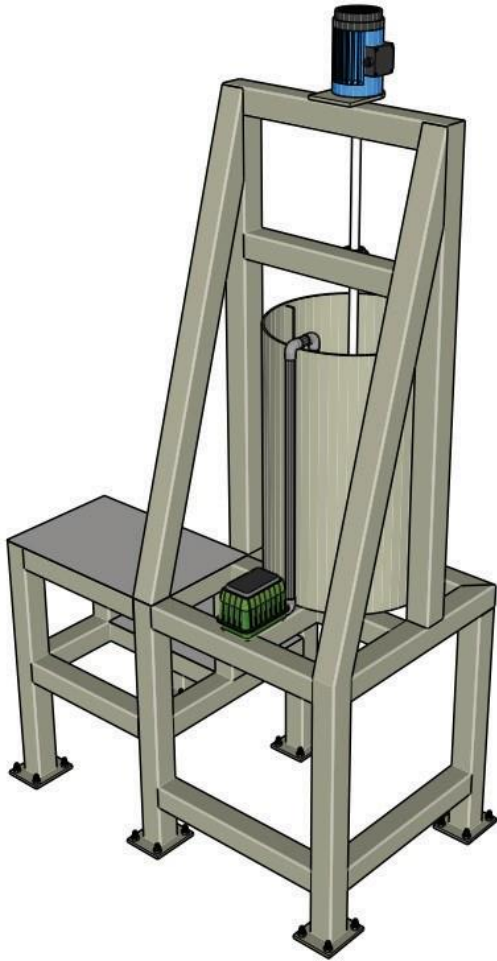

### Specifications:

- Material: Stainless Steel
- Capacity: 40-50 kg of ore, 150/200 L of slurry
- Dimensions:
  - Beam: Hollow 75x75x3.2
  - Column: Hollow 75x75x3.2
  - Bracing: Hollow 75x75x3.2
- Steel plate: 3 mm thickness
- Base plate:
  - Dimension (length x width x thickness): 140x140x8 mm
  - Bolt: 24 pcs, Diameter 16 mm
- Completed with:
  - 1 pcs Aerator [ref. item no. 6] + compatible rubber hose (5 meter)
  - 1 set Agitator Stirrer
  - 1 unit Agitator Motor

### Agitator Stirrer for The 150 -200 liter Leaching Tank

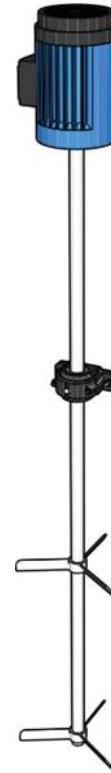

### Specifications:

Consisting of:

- Stirrer:
  - Material: SS 316 stainless steel
- Impeller:
  - 2 pairs of type 316 stainless steel graded blades
  - Diameter: 250mm
  - Thickness: 4 mm
  - Impeller-type hydrofoil
  - Finishing mechanical polish
  - material mixer SUS 304
- Agitator shaft:
  - Dimension: Length 1500 mm Diameter 30 mm
  - Double blade
  - Finishing mechanical polish
  - material mixer SUS 304
- Electric Motor:
  - Power source: 3 phases 1.5 HP / 0.75 kW electricmotor, 380 Volt, 50 Hz, 4 poles
  - Type: Vertical
  - RPM: 1500 rpm (with variable speed)
- Speed control inverter:
  - Inverter 0.75 kW 380V 3 Phase Variable FrequencyMotor Drive Speed Controller
  - Brand Schneider or Equivalent
- Gearbox inducer:
  - Type: helical gearhc01 or Equivalent
  - Ratio 1:4

## Detoxification Tank



### Specifications:

- Model: MX 500
- Capacity: 50 kg of ore, 500 L of slurry
- Size: Length x Width x Height (mm) 950 x 750 x 1100
- Weight: 42 kg
- Material: HDPE
- Material of Outer Case: DCD51D Gal Galvanized steel
- Specific Gravity of Load: 1.9
- Completed with:
  - Agitator stirrer
  - Speed control inverter
  - Motor
  - Carbon screen mesh

## Carbon Screen for Detoxification Tank

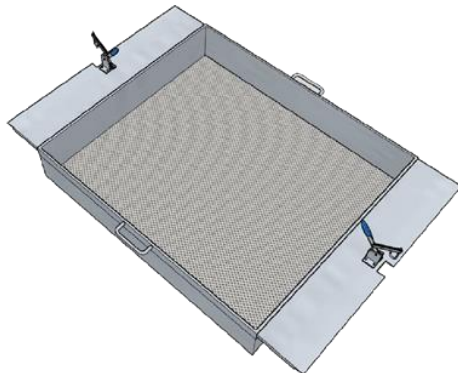

### Specifications:

- Sieve hole size: 35 mesh
- Sieve size: 1000 x 650 mm
- Sieve material: SS-316
- Sieve frame material: wood or plastic

## Agitator Stirrer for Detoxification Tank



### Specifications:

Consisting of:

- Working Capacity 200 - 1000 Liter
- Stirrer:
  - Material: SS 316 stainless steel
- Impeller:
  - Diameter impeller 250 mm and 4 mm Thickness
  - Impeller type hydrofoil/pitch blade
  - Material: Stainless Steel SUS 304
  - Finishing mechanical polish
- Agitator shaft:
  - Agitator shaft Dimension: Length 995 mm, Diameter 25.4 mm
  - Double Blade
- Electric Motor:
  - Power source: 3 phases 3 HP / 2.2 kW electric motor, 380 Volt, 50 Hz, 4 poles
  - Type: Horizontal
  - RPM: 1500 rpm
- Speed control inverter:
  - Power source: 3 phases 3 HP / 2.2 kW electric motor, 380 Volt, 50 Hz, 4 poles
  - Inverter 2.2 KW 380V 3 Phase Variable Frequency Motor Drive Speed Controller
  - Output: 3PH 0-500Hz
  - Control Method: voltage vector,
  - Braking Resistor: 250Ω
  - Rated voltage: three-phase AC380-440V
  - Brand Schneider or Equivalent
- Gearbox inducer:
  - Type: helical gearhc01 or Equivalent
  - Ratio 1:4

### Air Compressor for Smelting



#### Specifications:

Swan or equivalent  
Power: 550 W, Voltage / Freq: 220 V / 50 Hz  
Insulation Class / Grade: B  
Air Output: 112 L / min  
Working Pressure: 8 Bar,  
Cylinder diameter: 64 mm

### Booster Water Pump



#### Specifications:

Max pump BM-15/9 booster water pump or equivalent)  
Power: 100 Watt/0.5 A  
Voltage: 220 Volt/ 50 Hz/ 3uf  
Temperature: max. 110 Celcius  
Flow max: 30L/min

### Fresh Water Pump



#### Specifications:

Jet Pump Shimizu – PC 260 BIT – 250 WATT  
Voltage/Hz: - 220/50  
Motor Output Power: - 250 W  
Motor Input Power: - 0.6 kW  
Suction pipe length: - 30 m  
Head (m): - 24,  
Capacity: - 30 l/min  
Suction pipe 1 1/4 inch  
Pressure pipe: - 1 inch  
Weight: - 20 kg  
Automatic

## Booster Water Submersible Pump



### Specifications:

Tsurumi submersible pump for slurry or equivalent

Model Number: HS2.55 S or equivalent

Power: 550 Watt 1Phase  
Outlet: 2 inch

Completed with water hose compatible with the submersible pump

Outlet 2 inch  
10 Meter

## Aerator



### Specifications:

Brand: Resun Type LP 100 (or equivalent),

Power source: 100 W, 220 – 240 V, 50/60 Hz Watt,

Output: 140L/minute,

Note:

2 units for the 150-liter leaching tank

2 units for the 600-liter leaching tank

## Sump Box

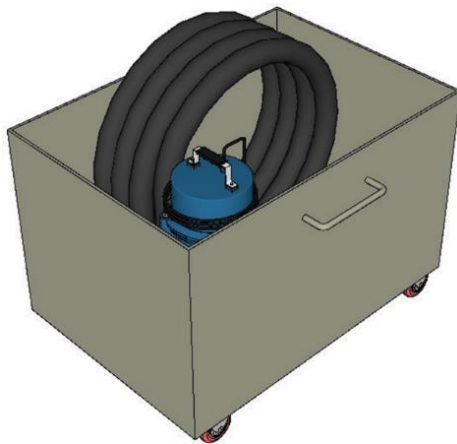

### Specifications:

Material: - steel

Capacity: - 100 L

Dimension: - 60x42x38 cm

Purpose: - as temporary container for the slurry (mixture of grounded ore and water) prior to the leaching and detoxification processes

Completed with: - wheels for easy movement  
submersible pump (removable)

**Tailing Treatment Pond Sketch.** (UNIT: mm)

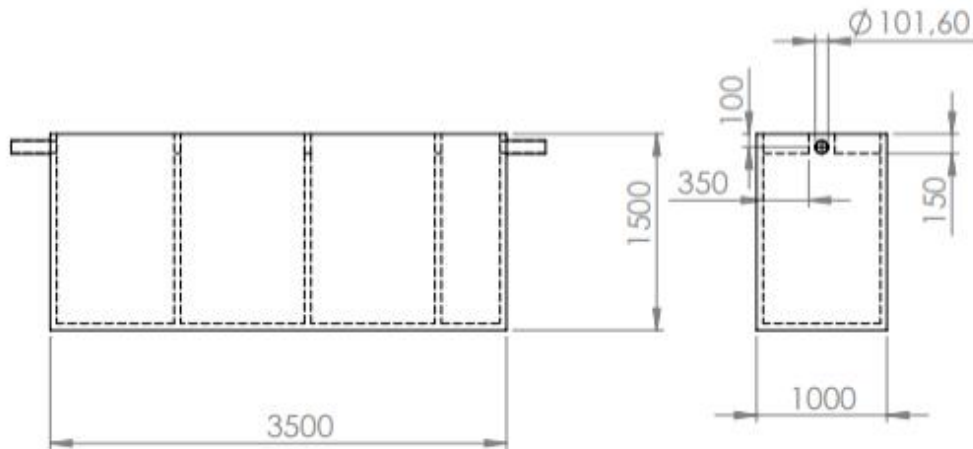
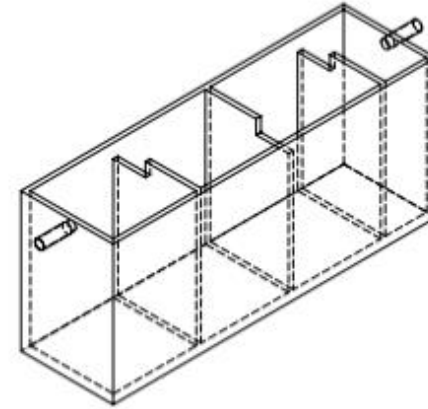
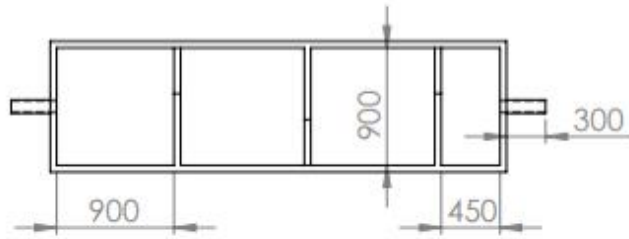

## EQUIPMENT COSTINGS

### Costings for the Training Plant Equipment & Installations

#### *Ore Processing Line*

Item #	Description	UOM	Quantity	Unit Cost (USD)	Total Cost (USD)
1	1m <sup>3</sup> Feed Hopper & Bin	unit	1	1,000	1,000
2	300mm x 500mm Jaw crusher	unit	1	3,500	3,500
3	Panel vibrating screen	unit	1	1,000	1,000
4	2ft Hammer mill	unit	1	2,500	2,500
5	Roller Ballmill	unit	1	4,000	4,000
6	Spiral classifier	unit	1	2,500	2,500
7	Steel cone concentrate storage	unit	1	1,000	1,000
8	Translucent plastic concentrate storage	unit	1	150	150
9	Underground plastic waste water tank	unit	1	500	500
10	Shaker table	unit	1	3,500	3,500
11	Gemeni shaker table	unit	1	2,500	2,500
12	5m <sup>3</sup> Overhead clean plastic water tank	unit	1	350	350
13	20m <sup>3</sup> Overhead clean plastic water tank	unit	1	500	500
14	400mm Conveyor belts	m	100	35	3,500
15	Conveyor belt drives ( motor and gearbox)	units	7	350	2,450
16	2 inch uPVC pipes	m	200	10	2,000
17	3 inch pipes	m	100	15	1,500
18	3/2 warman slurry pumps	units	1	2,500	2,500
19	Gold centrifugal gravity concentrator	units	1	3,500	3,500
20	Diesel-Powered Water Pump Generator (complete with 10 m inlet and 100m uPVC hosepipe)	unit	1	500	500
	<b>Sub-Total A</b>				<b>38,950</b>

**Gravimetric Processing Line**

Item #	Description	UOM	Quantity	Unit Cost (USD)	Total Cost (USD)
1	1 ton/hr wet ball-mill	unit	1	5,500	5,500
2	Chilean wet pan mill	unit	1	3,500	3,500
3	10m <sup>3</sup> Overhead clean plastic water tank	unit	1	800	800
4	Gold Kacha	unit	1	3,000	3,000
5	Sluice Boxes Fabrications	unit	1	2,000	2,000
6	Underground waste water tank	unit	1	500	500
7	Gold Cube / Konka	unit	1	2,000	2,000
8	Keene Super Concentrator Sluice	unit	1	1,000	1,000
9	Spiral Gold Concentrator	unit	1	1,000	1,000
10	Blue Bowl Vortex Concentrator	set	1	500	500
11	Bucket Sluice Concentrator	unit	1	250	250
12	Diesel-Powered Water Pump Generator (complete with 10 m inlet and 100m outlet uPVC hosepipe)		1	500	500
13	Set of gold washing pan and kit	set	1	200	200
14	Gold Concentrate Smelting Furnace	unit	1	500	500
15	Crucible, Tongs, Cuppel & Gold Molds	set	1	500	500
	<b>Sub-Total B</b>				<b>21,750</b>

**Leaching Processing Line**

Item #	Description	UOM	Quantity	Unit Cost (USD)	Total Cost (USD)
1	Indonesian 600-Liter Micro Leaching Tank	unit	2	2,000	4,000
2	Leaching Chemicals & Testing Reagents	LS	1	1,000	1,000
3	Mini Laboratory	LS	1	1,500	1,500
4	Detoxification Tank	unit	1	500	500
5	Tailings Treatment Pond	unit	1	1,000	1,000
6	Underground waste water tank	unit	1	500	500
7	Carbon Smelting Furnace	unit	1	500	500
8	Fresh Water Storage Tanks (500L, 1500L, 3000L, 5000L)	unit	1	500	500
9	500/600 Liter Steel Leaching Tank (To be locally Fabricated)	unit	1	1,000	1,000
10	150/200 Liter Steel Leaching Tank (To be locally Fabricated)	unit	1	1,000	1,000

11	Air Compressor for Smelting	unit	1	1,350	1,350
12	Booster Water Pump (Chemical waste tank)	unit	1	500	500
13	Fresh Water Pump	unit	1	500	500
14	Booster Submersible Water Pump (waste water)	unit	1	1,000	1,000
15	Sump Box	unit	1	125	125
<b>Sub-Total C</b>					<b>14,975</b>

***Additional Items***

Item #	Description	UOM	Quantity	Unit Cost (USD)	Total Cost (USD)
1	Temporary Store Structure (Iron-sheet)	LS	1	500	500
2	Solar Lighting system & Security	set	1	500	500
3	Site Preparation of Plant Site & Layout for equipment installations	LS	1	500	500
4	Briquette making Machine	LS	1	1,500	1,500
5	Miscellaneous for Fabrications & Materials	LS	1	1,000	1,000
<b>Sub-Total D</b>					<b>4,000</b>

**GRAND TOTAL COST**

Item #	Description	UOM	Quantity	Unit Cost (USD)	Total Cost (USD)
A	Sub-Total A (Ore Processing Line)	LS	1	38,950	38,950
B	Sub-Total B (Gravimetric Line)	LS	7	21,750	152,250
C	Sub-Total C (Micro-Leaching Line)	LS	7	14,975	104,825
D	Sub-Total D (Additional Items)	LS	1	4,000	4,000
<b>GRAND TOTAL</b>					<b>300,025</b>



Supported by:



Led by:



In partnership with:

